

Mathematics

SESSION 1

You may use your reference sheet during this session.
You may **not** use a calculator during this session.



DIRECTIONS

This session contains fourteen multiple-choice questions, four short-answer questions, and three open-response questions. Mark your answers to these questions in the spaces provided in your Student Answer Booklet.

- 1 In the diagram below, point M is the midpoint of \overline{JK} .

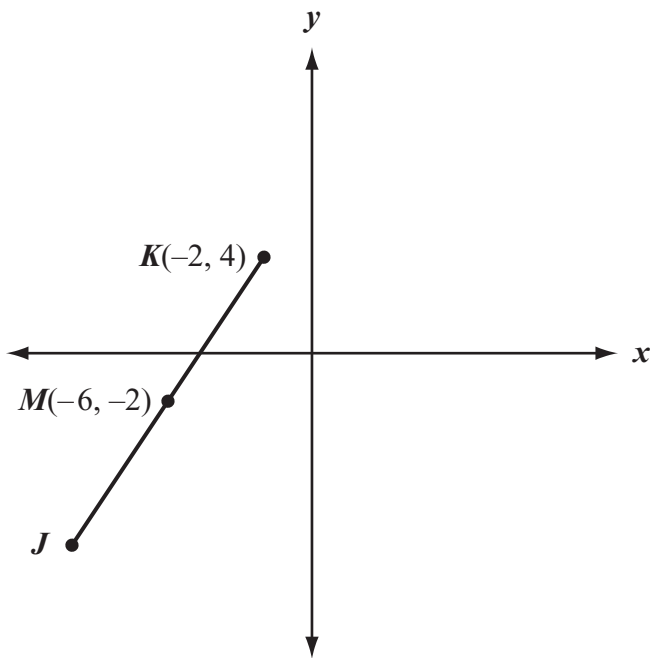

What are the coordinates of point J ?

- A. $(-4, 1)$
- B. $(-8, 2)$
- C. $(-10, -4)$
- D. $(-10, -8)$

- 2 A circle has an area of 16π square centimeters. What is the circumference of the circle?

- A. 32π centimeters
- B. 16π centimeters
- C. 8π centimeters
- D. 4π centimeters

- 3 Which of the following equations best represents the line of best fit for the scatterplot below?

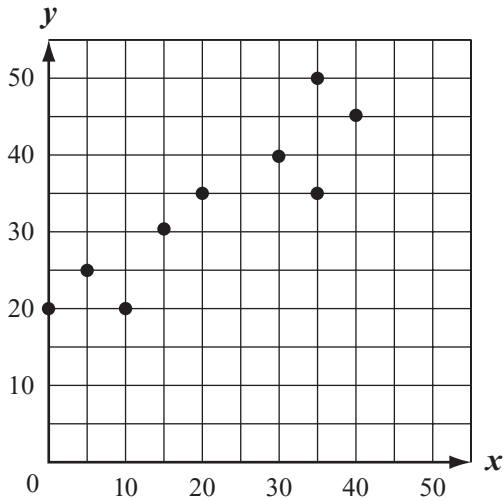

- A. $y = \frac{2}{3}x + 20$
- B. $y = \frac{3}{2}x + 20$
- C. $y = -\frac{2}{3}x + 20$
- D. $y = -\frac{3}{2}x + 20$

- 4 The bar graph below shows the one-year rate quotes Sanjay received from different car insurance companies.

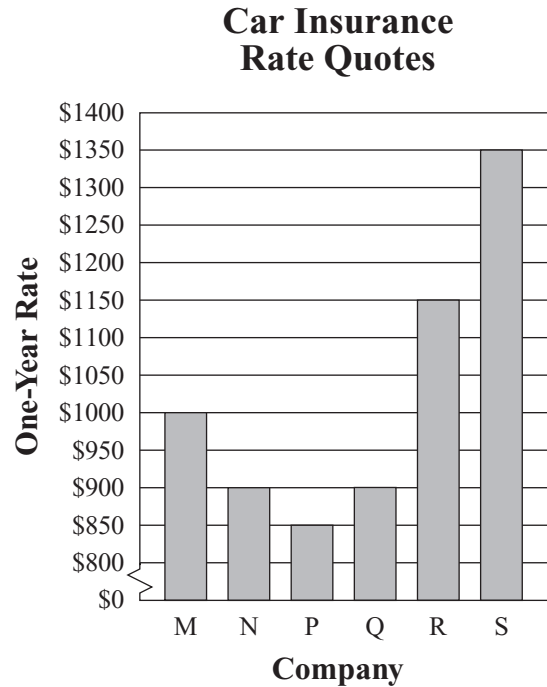

What is the mean one-year rate for the quotes Sanjay received?

- A. \$875
- B. \$900
- C. \$950
- D. \$1025

- 5 What is the **x-intercept** of the line represented by the equation below?

$$3x + 6y = 30$$

- A. 2
- B. 6
- C. 10
- D. 30

- 6 A new computer can perform 6.0×10^8 computations in 1 second. How many computations can the computer perform in 60 seconds?

- A. 1.0×10^7
- B. 1.0×10^9
- C. 3.6×10^9
- D. 3.6×10^{10}

- 7 The expression below represents the area, in square meters, of a rectangle.

$$x^2 + 5x - 24$$

Which of the following pairs of expressions could represent the length and width, in meters, of the rectangle?

- A. $(x - 3)$ and $(x + 8)$
- B. $(x - 4)$ and $(x + 6)$
- C. $(x - 6)$ and $(x + 4)$
- D. $(x - 8)$ and $(x + 3)$

- 8 The table below shows the monthly rents charged for different apartments.

Apartment Rents

Apartment	Monthly Rent
1A	\$ 750
1B	\$ 800
1C	\$ 900
1D	\$1000
2A	\$ 950
2B	\$1250
2C	\$ 950
2D	\$ 900

What is the median monthly rent charged for the apartments?

- A. \$900
- B. \$925
- C. \$938
- D. \$975

- 9 A package of 12 bottles of water sells for \$3.89. The manager of a stadium spent a total of \$287.86 on bottles of water.

Which of the following is closest to the number of **bottles** of water the manager bought?

- A. 100
- B. 300
- C. 600
- D. 900

- 10 The first five terms of a linear sequence are shown below.

8, 6, 4, 2, 0, . . .

What is the 100th term in the sequence?

- A. -192
- B. -190
- C. -108
- D. -90

- 11 What is the value of the expression below?

$$|-8 + 6|$$

- A. -14
- B. -2
- C. 2
- D. 14

- 12 A square window has an area of 120 square feet. Which of the following is closest to the length of each side of the window?

- A. 9 feet
- B. 10 feet
- C. 11 feet
- D. 12 feet

- 13 The list in the box below shows the ticket prices for ten concerts scheduled at a stadium.

\$32, \$36, \$65, \$30, \$46, \$19, \$46, \$40, \$70, \$16
--

A ticket price of \$70 is added to the list. Which of the following measures of the data will change?

- A. range
 - B. median
 - C. maximum
 - D. minimum
-

- 14 What is the value of the expression below?

$$(\sqrt{3})^4$$

- A. 3
- B. 9
- C. 27
- D. 81

Questions 15 and 16 are short-answer questions. Write your answers to these questions in the boxes provided in your Student Answer Booklet. Do not write your answers in this test booklet. You may do your figuring in the test booklet.

- 15 What is the value of the expression below?

$$3(4 - 6)^3$$

- 16 The diagram below shows a right square pyramid.

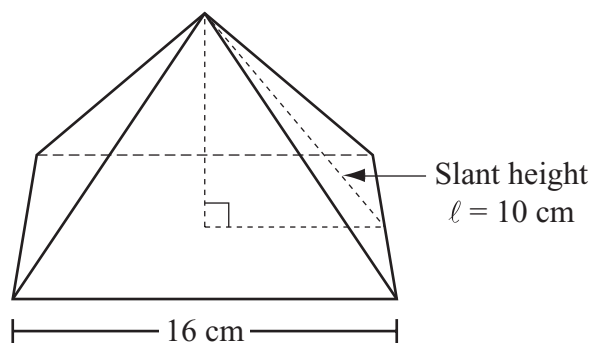

Based on the dimensions in the diagram, what is the lateral surface area, in square centimeters, of the pyramid?

Question 17 is an open-response question.

- **BE SURE TO ANSWER AND LABEL ALL PARTS OF THE QUESTION.**
- **Show all your work (diagrams, tables, or computations) in your Student Answer Booklet.**
- **If you do the work in your head, explain in writing how you did the work.**

Write your answer to question 17 in the space provided in your Student Answer Booklet.

- 17** A numerical expression is shown below.

$$\frac{8 \cdot 15 + 20 \div 5}{6 \div 3 \cdot 2}$$

- What is the value of the expression? Show or explain how you got your answer.
- Copy the equation below into your Student Answer Booklet.

$$\frac{8 \cdot 15 + 20 \div 5}{6 \div 3 \cdot 2} = 56$$

Insert sets of parentheses in the equation to make it true. Explain your reasoning.

- Copy the equation below into your Student Answer Booklet.

$$\frac{8 \cdot 15 + 20 \div 5}{6 \div 3 \cdot 2} = 38$$

Insert **one set** of parentheses in the equation to make it true. Explain your reasoning.

- Copy the expression below into your Student Answer Booklet.

$$\frac{8 \cdot 15 + 20 \div 5}{6 \div 3 \cdot 2}$$

Insert a set or sets of parentheses in the expression so that the expression will have a value that is **not** equal to 38, 56, or the answer to part (a). Explain your reasoning.

Questions 18 and 19 are short-answer questions. Write your answers to these questions in the boxes provided in your Student Answer Booklet. Do not write your answers in this test booklet. You may do your figuring in the test booklet.

- 18 The table below shows a linear relationship between the values of x and y .

x	1	2	3	4
y	3	9	15	21

Based on the relationship shown in the table, what is the value of y when $x = 5$?

- 19 What is the value, to the nearest tenth, of $\sqrt{8}$?

Questions 20 and 21 are open-response questions.

- BE SURE TO ANSWER AND LABEL ALL PARTS OF EACH QUESTION.
- Show all your work (diagrams, tables, or computations) in your Student Answer Booklet.
- If you do the work in your head, explain in writing how you did the work.

Write your answer to question 20 in the space provided in your Student Answer Booklet.

20 Triangle JKL is shown on the coordinate plane below.

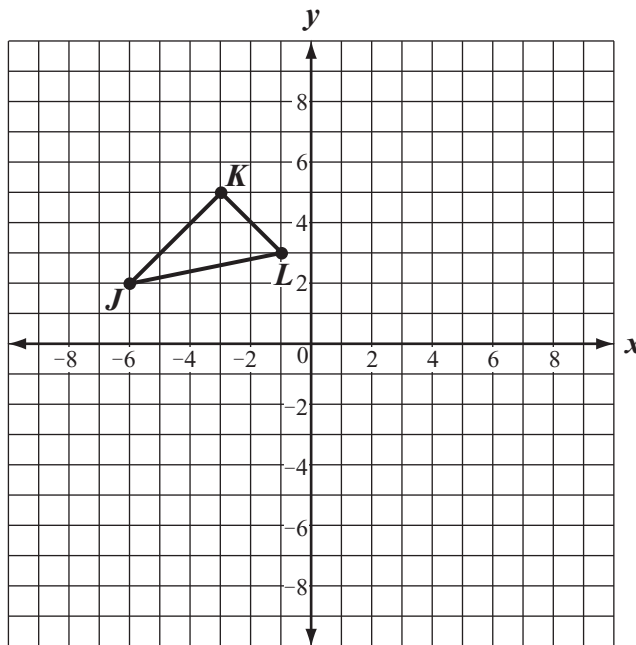

Copy the coordinate plane and triangle JKL as shown onto the grid in your Student Answer Booklet.

Triangle JKL is reflected over the y -axis.

- a. On your grid, draw triangle $J'K'L'$, the image of triangle JKL after it has been reflected over the y -axis. Be sure to label the vertices.

Triangle $J'K'L'$ is rotated 90° clockwise about the origin.

- b. On your grid, draw triangle $J''K''L''$, the image of $J'K'L'$ after it has been rotated 90° clockwise about the origin. Be sure to label the vertices.
- c. Suppose the vertices of $J''K''L''$ are reflected over the y -axis and then reflected over the x -axis. Do the vertices of the resulting triangle have the same coordinates as the vertices of triangle JKL ? Show or explain how you got your answer.

Write your answer to question 21 in the space provided in your Student Answer Booklet.

- 21** A person's score on a timed keyboarding test varies directly with the number of words the person types correctly. Each keyboarding test lasts the same amount of time.

On her first test, Catherine earned a score of 75 when she typed 200 words correctly.

- What is the ratio of Catherine's score to the number of words she typed correctly?
- Use your ratio from part (a) to write an equation that can be used to find y , the score for x words typed correctly.

On her second test, Catherine typed 240 words correctly.

- Use the equation you wrote in part (b) to find the score Catherine earned on her second test. Show or explain how you got your answer.

Catherine wants to earn a score of at least 96 on her third test.

- What is the least number of words Catherine must type correctly to earn a score of 96? Show or explain how you got your answer.

Mathematics

SESSION 2

You may use your reference sheet during this session.

You may use a calculator during this session.



DIRECTIONS

This session contains eighteen multiple-choice questions and three open-response questions. Mark your answers to these questions in the spaces provided in your Student Answer Booklet.

- 22 In the diagram below, lines h and j are parallel. Line k and line m intersect lines h and j .

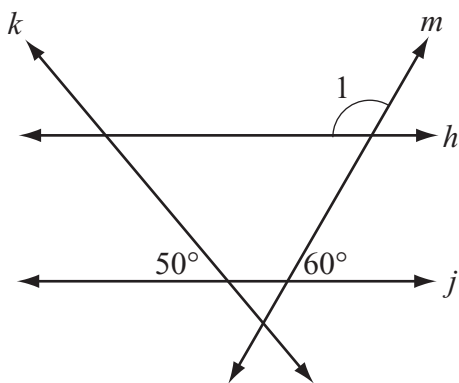

Based on the angle measures in the diagram, what is $m\angle 1$?

- A. 50°
- B. 60°
- C. 120°
- D. 130°

- 23 The circle graph below shows information about the budget for a school party.



The total budget for the party is \$1500.

What is the total dollar amount in the budget for entertainment?

- A. \$300
- B. \$450
- C. \$500
- D. \$1050

- 24 An inequality is shown below.

$$8 \leq x + 2 \leq 12$$

Which of the following graphs represents the solution of the inequality?

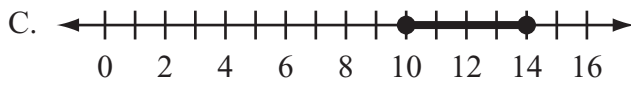
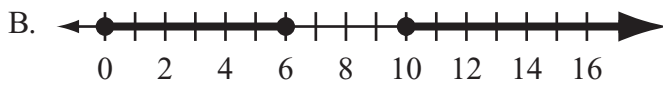
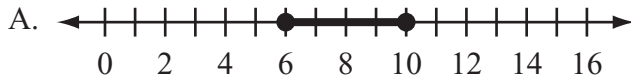

- 25 Six points are plotted on the coordinate grid below.

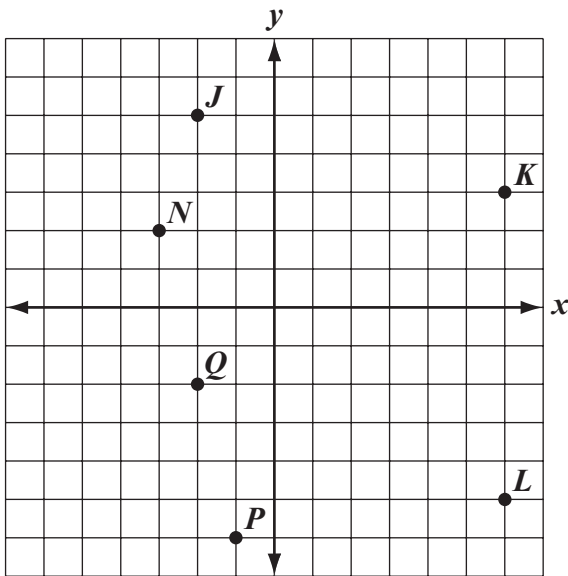

Which two points lie on a line with a slope closest to zero?

- A. *N* and *J*
- B. *N* and *K*
- C. *P* and *L*
- D. *P* and *Q*

- 26 A pizza restaurant uses small pans and large pans.

- Each pan is in the shape of a circle.
- The area of the large pan is 9 times the area of the small pan.

The radius of the large pan is how many times the radius of the small pan?

- A. 3
- B. 6
- C. 9
- D. 27

- 27 The histogram below shows the relationship between the price of a used car and the number of used cars sold.

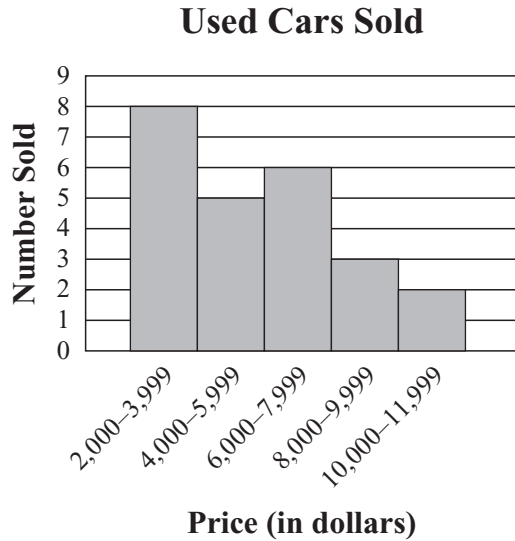

Based on the histogram, which statement **must** be true?

- A. No used car sold for \$7,000.
- B. Exactly 5 of the used cars sold for \$4,000.
- C. The most expensive used car sold for \$11,999.
- D. Most of the used cars sold for less than \$6,000.

- 28 The diagram below represents different connecting routes an airplane pilot can take to travel from one city to another.

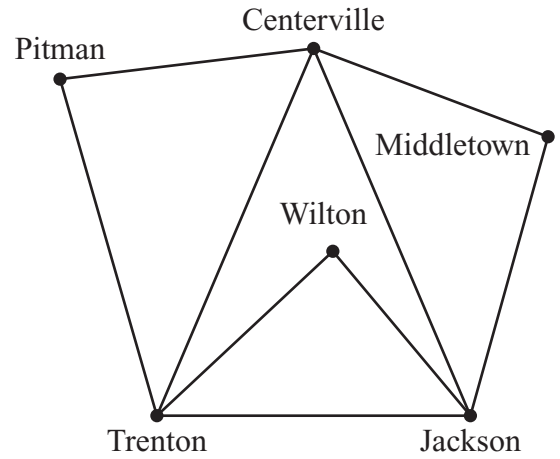

An airplane will fly from Middletown to Wilton. The pilot of the airplane wants to stop in no more than 2 cities between Middletown and Wilton.

How many different ways can the pilot fly from Middletown to Wilton?

- A. 1
- B. 2
- C. 3
- D. 4

- 29 Abby drew $\triangle FGJ$ and \overline{FH} , as shown in the diagram below.

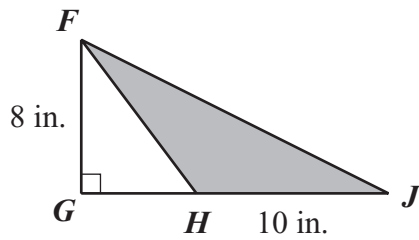

The figure in the diagram has the following properties:

- Point H lies on \overline{GJ} .
- The length of \overline{FG} is 8 inches.
- The length of \overline{HJ} is 10 inches.

What is the area of the shaded triangle, $\triangle FGH$?

- A. 80 sq. in.
- B. 64 sq. in.
- C. 48 sq. in.
- D. 40 sq. in.

- 30 Which of the following absolute-value inequalities best represents the graph shown on the number line below?





- A. $|x - 2| \leq 3$
- B. $|x - 2| \geq 3$
- C. $|x - 3| \leq 2$
- D. $|x - 3| \geq 2$

Questions 31 is an open-response question.

- **BE SURE TO ANSWER AND LABEL ALL PARTS OF THE QUESTION.**
- **Show all your work (diagrams, tables, or computations) in your Student Answer Booklet.**
- **If you do the work in your head, explain in writing how you did the work.**

Write your answer to question 31 in the space provided in your Student Answer Booklet.

- 31** Nicole’s rental company has only cars and vans available to rent. The poster below shows the rental costs per day for the vehicles at her company.

Rental Costs per Day	
Car: \$40	
Van: \$60	

- a. One day last week, the total rental income for Nicole’s company was \$460 for cars and vans together. Her company rented 7 cars that day. How many **vans** did her company rent that day? Show or explain how you got your answer.

For parts (b), (c), and (d), define c and v as follows:

- c = the number of cars the company owns
 - v = the number of vans the company owns
- b. The company owns a total of 36 vehicles. Write an equation in terms of c and v that represents this fact.
- c. On a day when Nicole’s company rents all its cars and vans, the total rental income is \$1700. Write an equation in terms of c and v that represents this fact.
- d. Use your equations from parts (b) and (c) to determine how many cars the company owns **and** how many vans the company owns. Show your work.

Mark your answers to multiple-choice questions 32 through 40 in the spaces provided in your Student Answer Booklet. Do not write your answers in this test booklet. You may do your figuring in the test booklet.

32 An athlete walked down 16 flights of stairs in 128 seconds.
At this rate, what is the total number of seconds it will take the athlete to walk down 21 flights of stairs?

- A. 98
- B. 133
- C. 168
- D. 336

33 Two angles of a triangle each measure 64° . What is the measure of the third angle of the triangle?

- A. 32°
- B. 52°
- C. 58°
- D. 64°

34 The table below shows the ticket costs for seats in different sections of a stadium.

Ticket Costs for Stadium Seats

Section	Ticket Cost per Seat
main	\$75
lower deck	\$59
upper deck	\$42
bleacher	\$22

What is the greatest number of bleacher seat tickets that can be bought for the cost of 12 lower deck seat tickets?

- A. 22
- B. 32
- C. 42
- D. 52

- 35 The amount of time it takes mail carriers to deliver the mail in one town is inversely proportional to the number of mail carriers delivering the mail. With 8 mail carriers, it takes 6 hours to deliver the town's mail.

What is the number of hours it would take 4 mail carriers to deliver the town's mail?

- A. 2
- B. 3
- C. 10
- D. 12

- 36 A stage floor is composed of a rectangle and an isosceles trapezoid. The diagram below shows the stage floor and some of its dimensions.

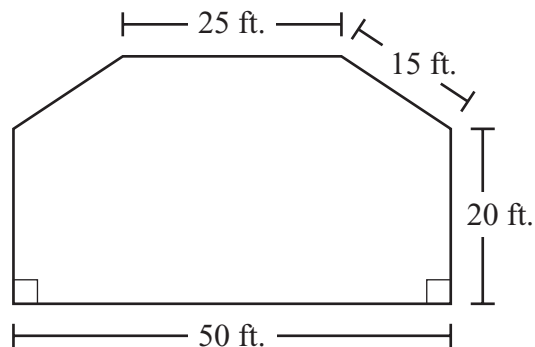

What is the perimeter of the stage floor?

- A. 110 ft.
- B. 145 ft.
- C. 1000 ft.
- D. 1375 ft.

- 37 A model of a skyscraper is 15 inches tall. The model uses the scale shown below.

Scale
0.5 inch : 12 yards

Which of the following proportions can be used to find x , the height in yards of the actual skyscraper?

- A. $\frac{15}{12} = \frac{0.5}{x}$
- B. $\frac{15}{x} = \frac{0.5}{12}$
- C. $\frac{0.5}{15} = \frac{x}{12}$
- D. $\frac{0.5}{12} = \frac{x}{15}$

- 38 The price per pound of each kind of vegetable sold at a farmers' market is shown in the table below.

Prices per Pound (\$)

0.95	0.70	1.25	1.49
1.49	0.95	0.95	1.25
1.20	1.99	1.99	1.49
0.45	1.49	1.25	0.60

What is the mode of the prices per pound for the vegetables?

- A. \$0.95
- B. \$1.25
- C. \$1.49
- D. \$1.99

39 Ken and Jerome went to the same electronics store.

- Ken bought 2 video games and 1 DVD for a total of \$105.
- Jerome bought 1 video game and 4 DVDs for a total of \$105.

Each video game cost v dollars and each DVD cost d dollars.

Which system of equations can be used to find the cost, in dollars, of each video game and each DVD at the store?

- A. $v + 2d = 105$
 $v + 4d = 105$
- B. $2v + d = 105$
 $4v + d = 105$
- C. $2v + d = 105$
 $v + 4d = 105$
- D. $2v + 4d = 105$
 $v + d = 105$

40 The diagram below shows a parallelogram and its dimensions.

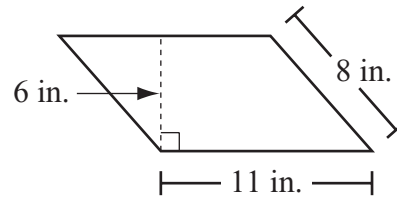

What is the area of the parallelogram?

- A. 38 sq. in.
- B. 48 sq. in.
- C. 66 sq. in.
- D. 88 sq. in.

Questions 41 and 42 are open-response questions.

- **BE SURE TO ANSWER AND LABEL ALL PARTS OF EACH QUESTION.**
- **Show all your work (diagrams, tables, or computations) in your Student Answer Booklet.**
- **If you do the work in your head, explain in writing how you did the work.**

Write your answer to question 41 in the space provided in your Student Answer Booklet.

- 41 The numbers of games won and lost by six local baseball teams are shown in the double bar graph below.

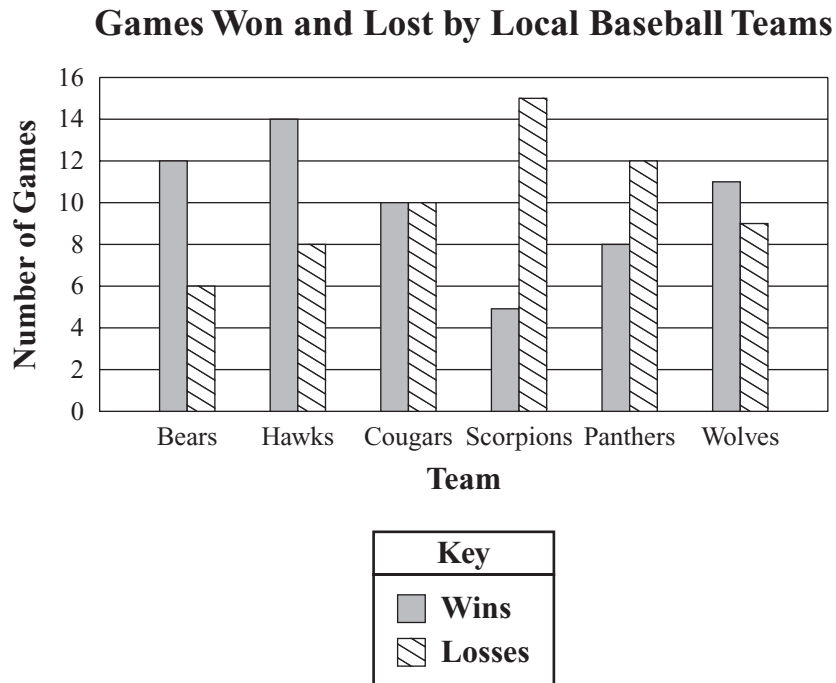

- How many more games did the Hawks win than the Wolves won? Show or explain how you got your answer.
- For the Panthers, what is the ratio of games won to games **played**? Show or explain how you got your answer.
- Which of the six teams has the greatest ratio of games won to games played? Show or explain how you got your answer.

The Scorpions later played additional games that were not included in the double bar graph. The additional games changed the Scorpions' ratio of games won to games played to $\frac{1}{2}$.

- What is the least number of **additional** games the Scorpions could have played? Show or explain how you got your answer.

Write your answer to question 42 in the space provided in your Student Answer Booklet.

- 42 A company manufactures solid glass spheres. Each sphere has a radius of 2 inches and is packed in a gift box shaped like a cube. The box is small enough so that each side of the box touches the sphere.
- What is the length, in inches, of each edge of the box? Show or explain how you got your answer.
 - What is the volume, in cubic inches, of the box? Show your work.

Material is added to the spaces around the glass spheres in the boxes to prevent breakage.

- What is the volume, in cubic inches, of the space inside the box but outside the sphere? Show your work.

The company wants to pack multiple cube-shaped boxes into large boxes for shipping. Each large box is in the shape of a right rectangular prism and has a length of 24 inches, a width of 20 inches, and a height of 16 inches.

- What is the maximum number of cube-shaped boxes that can fit inside a large box? Show your work.

Grade 10 Mathematics
Spring 2011 Released Items:
Reporting Categories, Standards, and Correct Answers*

Item No.	Page No.	Reporting Category	Standard	Correct Answer (MC/SA)*
1	245	<i>Geometry</i>	10.G.7	D
2	245	<i>Measurement</i>	10.M.1	C
3	246	<i>Data Analysis, Statistics, and Probability</i>	10.D.2	A
4	246	<i>Data Analysis, Statistics, and Probability</i>	10.D.1	D
5	247	<i>Patterns, Relations, and Algebra</i>	10.P.2	C
6	247	<i>Number Sense and Operations</i>	10.N.2	D
7	247	<i>Patterns, Relations, and Algebra</i>	10.P.4	A
8	247	<i>Data Analysis, Statistics, and Probability</i>	10.D.1	B
9	248	<i>Number Sense and Operations</i>	10.N.4	D
10	248	<i>Patterns, Relations, and Algebra</i>	10.P.1	B
11	248	<i>Number Sense and Operations</i>	10.N.2	C
12	248	<i>Number Sense and Operations</i>	10.N.3	C
13	249	<i>Data Analysis, Statistics, and Probability</i>	10.D.1	B
14	249	<i>Number Sense and Operations</i>	10.N.1	B
15	250	<i>Number Sense and Operations</i>	10.N.2	-24
16	250	<i>Measurement</i>	10.M.2	320 cm ²
17	251	<i>Number Sense and Operations</i>	10.N.2	
18	252	<i>Patterns, Relations, and Algebra</i>	10.P.1	27
19	252	<i>Number Sense and Operations</i>	10.N.3	2.8
20	253	<i>Geometry</i>	10.G.9	
21	254	<i>Patterns, Relations, and Algebra</i>	10.P.7	
22	255	<i>Geometry</i>	10.G.3	C
23	255	<i>Data Analysis, Statistics, and Probability</i>	10.D.1	B
24	256	<i>Patterns, Relations, and Algebra</i>	10.P.6	A
25	257	<i>Patterns, Relations, and Algebra</i>	10.P.2	B
26	257	<i>Measurement</i>	10.M.3	A
27	258	<i>Data Analysis, Statistics, and Probability</i>	10.D.1	D
28	258	<i>Geometry</i>	10.G.11	D
29	259	<i>Measurement</i>	10.M.1	D
30	259	<i>Patterns, Relations, and Algebra</i>	10.P.6	A
31	260	<i>Patterns, Relations, and Algebra</i>	10.P.8	
32	261	<i>Number Sense and Operations</i>	8.N.3	C
33	261	<i>Geometry</i>	10.G.5	B
34	261	<i>Data Analysis, Statistics, and Probability</i>	10.D.1	B
35	262	<i>Patterns, Relations, and Algebra</i>	10.P.7	D
36	262	<i>Measurement</i>	10.M.1	B
37	263	<i>Patterns, Relations, and Algebra</i>	10.P.7	B
38	263	<i>Data Analysis, Statistics, and Probability</i>	10.D.1	C
39	264	<i>Patterns, Relations, and Algebra</i>	10.P.8	C
40	264	<i>Measurement</i>	10.M.1	C
41	265	<i>Data Analysis, Statistics, and Probability</i>	10.D.1	
42	266	<i>Measurement</i>	10.M.2	

* Answers are provided here for multiple-choice items and short-answer items only. Sample responses and scoring guidelines for open-response items, which are indicated by shaded cells, will be posted to the Department's website later this year.