

# Grade 6

Assessment of Reading, Writing and Mathematics, Junior Division

## Student Booklet

# Mathematics

Spring 2013

### **RELEASED ASSESSMENT QUESTIONS**

**Record your answers on the Multiple-Choice  
Answer Sheet.**

Beginning in 2013, EQAO will make approximately half, rather than all, of its test items (questions) public after each assessment. This process allows EQAO to build up a bank of items that can be used in future years.

The best practice for supporting students is to review their achievement of the knowledge or skills being assessed, rather than focus on the specific test items. To facilitate that process, items that are not being published have been described in this booklet, including a reference to the knowledge or skill they assessed. Test booklets and examples of student answers from the past five years also remain available at [www.eqao.com](http://www.eqao.com).

Education Quality and  
Accountability Office



- 1** Points P and Q are two vertices of a rectangle.

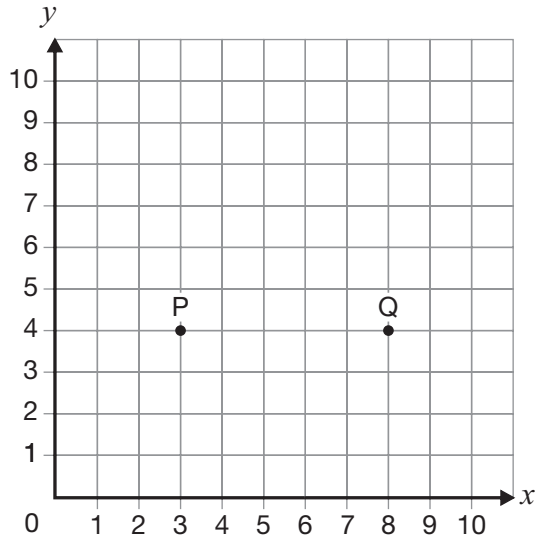

Which set of ordered pairs could represent the other two vertices of the rectangle?

- a (4, 8) and (9, 8)
- b (8, 4) and (8, 9)
- c (1, 3) and (1, 8)
- d (3, 1) and (8, 1)

- 2** Mrs. Sherman asks students to record their favourite subjects. The data is shown in the graph below.

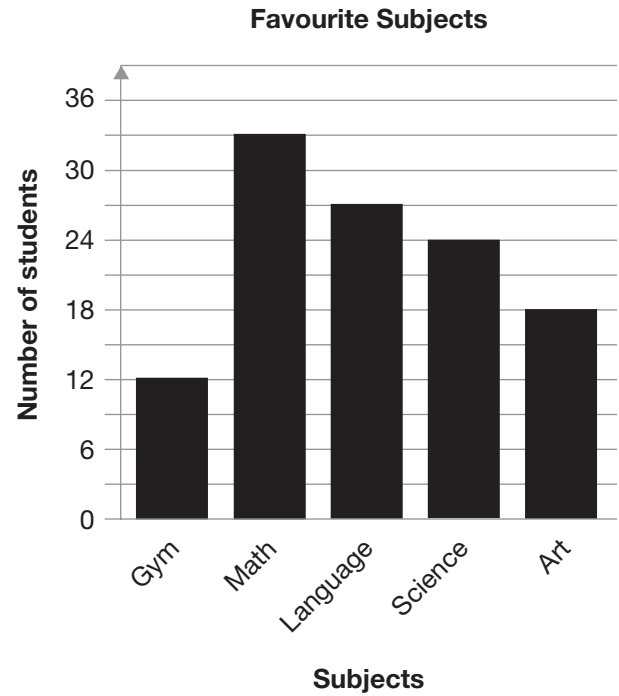

According to the graph, how many more students chose math as their favourite subject than chose gym?

- a 7
- b 12
- c 21
- d 33

- 3** Consider the growing pattern shown on the grid below.

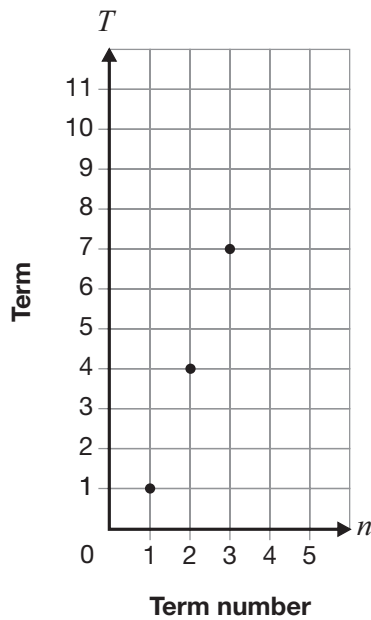

The pattern continues in the same way. What ordered pair represents the next point to be plotted in this pattern?

- a (4, 9)
  - b (10, 4)
  - c (9, 4)
  - d (4, 10)
- 4** There are 12 books in a case. There are 6 cases in a box and 24 boxes in a container.



If each container of books costs \$2592, what is the cost of one book?

- a \$1.50
- b \$9.00
- c \$18.00
- d \$36.00

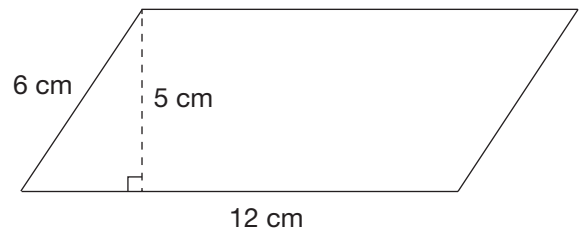
- 5** A parallelogram is shown below.

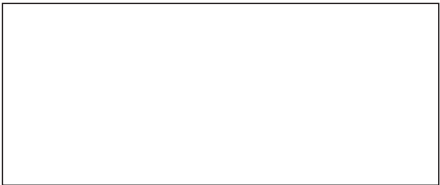
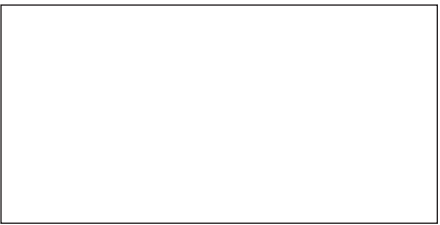

Which rectangle has the same area as this parallelogram?

- a 
- b 
- c 
- d 

- 6** If  $n \times 3 = 24$  and  $n + 40 - s = 36$ , what is the value of  $s$ ?
- a 8
  - b 10
  - c 12
  - d 14

- 7** The diagram below shows a shoebox without a lid.

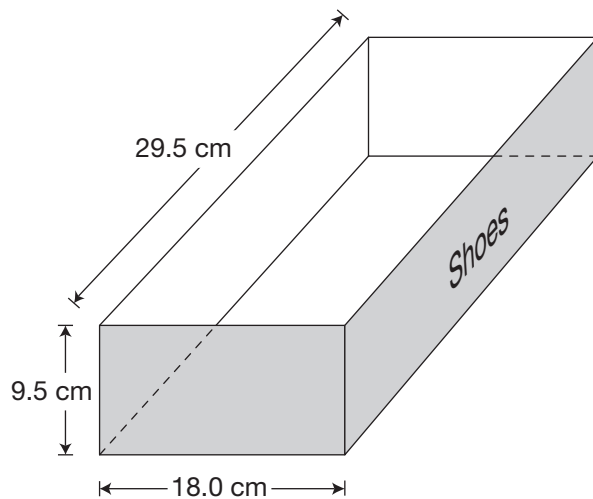

A student covers the outside of the shoebox with construction paper.

If the student does not cover the lid, what is the surface area that is covered?

- a  $982.25 \text{ cm}^2$
- b  $1433.50 \text{ cm}^2$
- c  $1964.50 \text{ cm}^2$
- d  $5044.50 \text{ cm}^2$

- 8** A store has 11.2 kg of potatoes. Maria buys 572 g of potatoes from the store and Colin buys 1.42 kg of potatoes from the store.

After these two purchases, how many grams of potatoes does the store have left?  
Show your work.

The store has \_\_\_\_\_ grams of potatoes left.

- 9** Rotate the hexagon below  $90^\circ$  counter-clockwise about Point X. Draw this image of the hexagon.

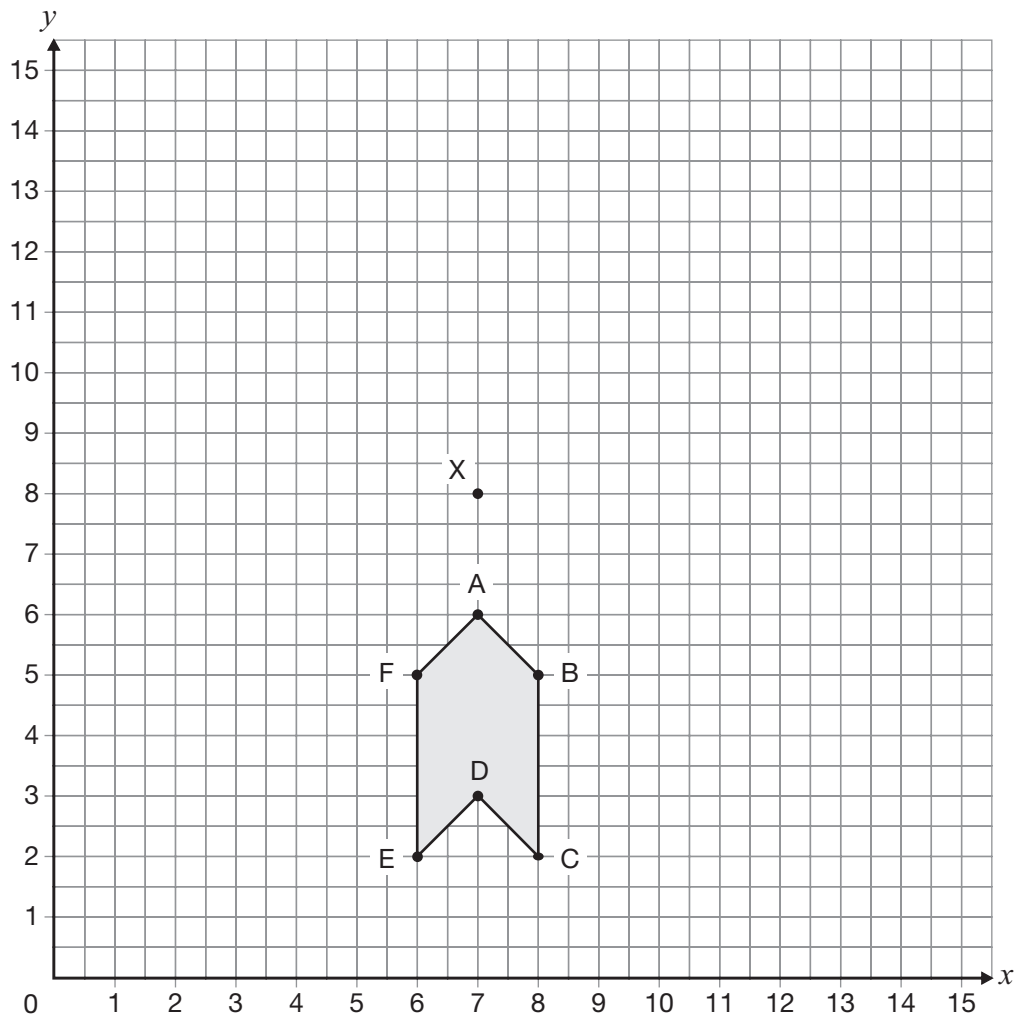

Record the coordinates of the image of Point C.

Image of Point C: (   ,   )

- 10** Consider the two spinners below. Spinner A is divided into 10 equal sections, and Spinner B is divided into 5 equal sections.

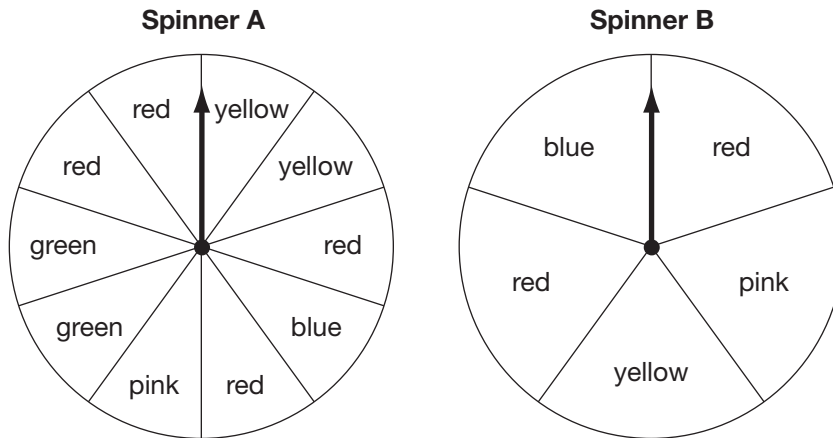

Which colours have the same probability of being spun on Spinner A as they do on Spinner B?  
Justify your answers.

**11** A Grade 6 class is having a fundraiser.

The class buys 3 bags of apples. Each bag has 24 apples. The total cost of the 3 bags of apples is \$12.24.

The class sells the apples for \$0.75 each.

How much money will the class gain per apple?

Show your work.

The class gains \_\_\_\_\_ per apple.



**12** Which of the following fractions has the smallest value?

- a  $\frac{4}{5}$
- b  $\frac{4}{4}$
- c  $\frac{4}{3}$
- d  $\frac{4}{2}$

**13** There are 2 blue, 5 green, 6 red and 7 purple marbles in a bag. Erin picks one marble from the bag without looking.

What is the probability that she will pick a marble that is purple?

- a 7%
- b 20%
- c 35%
- d 54%

**14** Wasim's hair grows 0.4 cm each week.

At this rate, which is closest to the increase in length of Wasim's hair over 3 months if it is not cut?

- a 1 cm
- b 5 cm
- c 8 cm
- d 12 cm

**15** Consider the repeating pattern below.



If the pattern continues in the same way, what will the 54th term be?

- a
- b
- c
- d

**16** Which set of data has a mean that is equal to its median?

- a 4, 5, 5, 7, 9
- b 4, 5, 6, 7, 8
- c 4, 4, 6, 7, 7, 7, 7
- d 5, 5, 5, 5, 6, 8, 8

**17** What unit of measure is the most appropriate to estimate the thickness of a dime?

- a cm
- b dam
- c m
- d mm

**18** What type of angle is shown below?

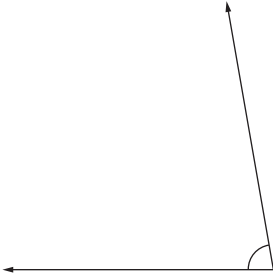

- a acute
- b right
- c obtuse
- d straight

